

# ***KOBELT***

## **7040 STEERING CYLINDER**

*Owner's Operation, Installation &  
Maintenance Manual*



APRIL 2021

**NOTES:**

---



---



---



---



---



---



---



---



---



---



---



---



---



---



---



---



---



---



---



---



---



---

<b>RECORD DATA BEFORE INSTALLATION FOR FUTURE REFERENCE</b>	
<b>Model #:</b>	
<b>Serial #:</b>	
<b>Date of Purchase:</b>	
<b>Date of Installation:</b>	

---

# TABLE OF CONTENTS

---

<b>1</b>	<b>Introduction .....</b>	<b>4</b>
1.1	Contact .....	4
1.2	Compliant Use .....	4
1.3	Copyrights & Trademarks .....	4
<b>2</b>	<b>Safety.....</b>	<b>5</b>
2.1	Safety Alerts.....	5
2.2	Notice to Installer .....	5
<b>3</b>	<b>Product Description .....</b>	<b>6</b>
3.1	Technical Specifications .....	6
<b>4</b>	<b>Installation .....</b>	<b>7</b>
4.1	Mechanical .....	7
4.2	Hydraulic.....	10
<b>5</b>	<b>Commissioning .....</b>	<b>11</b>
5.1	Flushing.....	11
5.2	Inspection & Function test.....	11
5.3	Hydraulic Fill & Bleed .....	12
<b>6</b>	<b>Maintenance .....</b>	<b>13</b>
6.1	Preventative Maintenance.....	13
6.2	Recommended Spare Parts.....	13
<b>7</b>	<b>Warranty.....</b>	<b>14</b>
<b>8</b>	<b>Appendix A: Parts List.....</b>	<b>15</b>

---

# 1 INTRODUCTION

---

## 1.1 CONTACT

**Kobel Manufacturing Co. Ltd.**  
8238-129th Street  
Surrey, British Columbia  
Canada, V3W 0A6

Sales Tel: +1-604-572-3935  
Fax: +1-604-590-8313  
Email: [sales@kobelt.com](mailto:sales@kobelt.com)  
Website: [www.kobelt.com](http://www.kobelt.com)

This document is intended to clearly present comprehensive product data and provide technical information to assist the end user in design applications. Kobelt reserves the right, without notice, to change the design, or construction, of any products and to discontinue or limit distribution of any products. Kobelt also reserves the right to change, or update, without notice, any technical information contained within this document.

Kobel recommends that customers visit our website to check for updates to this Manual. Once a product has been selected for use, it should be tested by the user to ensure proper function in all possible applications. For further instructions, please contact our distributors or visit our website.

## 1.2 COMPLIANT USE

This device is only intended for use by persons trained in operating marine systems.

The installer shall:

- Only use non-defective products.
- Check the safety of operation and the condition of the device before each use.
- Verify that the product is operational at all times and keep it in good working conditions.

Only Kobelt Manufacturing Co. Ltd. Authorized Dealers or Authorized Technicians are to repair Kobelt products.



## 1.3 COPYRIGHTS & TRADEMARKS

All product names, logos and brands are property of their respective owners. All company, product and service names used in this manual are for identification purposes only. Use of these names, logos, and brands does not imply endorsement.

## 2 SAFETY

### 2.1 SAFETY ALERTS

Throughout this manual, the following symbols, and their accompanying explanation, are used to alert the user to special instructions concerning a service or operation that may be hazardous if performed incorrectly or carelessly. The associated risk levels are stated below.

 <b>DANGER</b>	This symbol indicates an imminently hazardous situation which, if not avoided, will result in death or serious injury.
 <b>WARNING</b>	This symbol indicates a potentially hazardous situation which, if not avoided, could result in death or serious injury.
 <b>CAUTION</b>	This symbol indicates a hazardous situation, which if not avoided, could result in minor or moderate injury.
<b>NOTICE</b>	This symbol informs the reader of events not related to personal injury but which there is a risk of damage to property or equipment.
<b>SAFETY INSTRUCTIONS</b>	This symbol informs the reader of safety-related instructions or procedures.

### 2.2 NOTICE TO INSTALLER

Disregarding the following safety measures can result in an accident causing severe injury to personnel and damage to material assets.

- Only use the product as directed in this manual.
- Never put the product into service if there is evidence of visible damage.
- Never put the product into service before fully completing installation and commissioning.
- Do not carry out any modifications to the product.
- Only use authentic Kobelt spare parts.
- Observe all local regulations, directives and laws during the installation of this product.
- All installation, commissioning, and maintenance work must only be conducted by qualified personnel. (For the purpose of this manual, qualified personnel are persons who are familiar with the assembly, installation, commissioning, and operation of the product and who have the qualifications necessary for their occupation.)
- Observe all specifications in this manual. If these guidelines are not followed and damage occurs, the warranty will be voided.

### 3 PRODUCT DESCRIPTION

The 7040 steering cylinder is durable, solid cylinder that offers strength and flexibility in sizing and rudder movement for marine vessels, available in balanced and unbalanced versions.

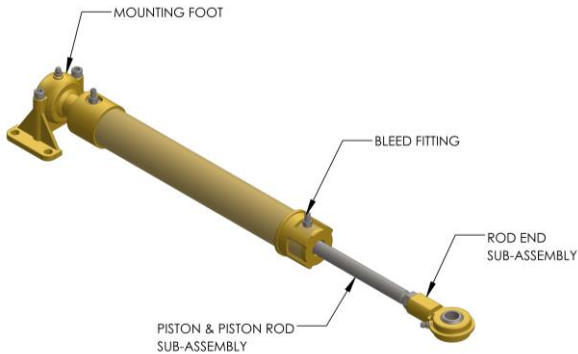

Figure 1: 7040 Cylinder Overview Diagram

#### 3.1 TECHNICAL SPECIFICATIONS

Table 1: Cylinder Technical Specifications

MODEL	7040
DESIGN PRESSURE	1500 psi [103 Bar]
WORKING PRESSURE	1200 psi [83 Bar]
BORE DIAMETER	1.50 in
ROD DIAMETER	0.625 in
PIN DIAMETER	0.625 in
PORT SIZE	1/4" NPT
RECOMMENDED FLUID	ISO VG 32, VI 60 Hydraulic Oil
OPERATING TEMPERATURE	-10°C to 50°C [14°F to 122°F]

##### 3.1.1 Temperature Limits

Observe the operating temperature range limits as presented in Table 1. Do not operate the system if the ambient temperature where the unit is located exceeds these limits.

**NOTICE**

Exceeding these temperatures may result in reduced operational life or damage to the product.

## 4 INSTALLATION

### 4.1 MECHANICAL

The 7040 cylinder is equipped with (4) four holes for 5/16" bolts through the mounting feet. Ensure that the unit is securely fastened to a suitable foundation.

Kobel requires a steering gear torque or rudder calculation be done before sizing or ordering any steering system, to ensure the correct mix of pressure, displacement, stroke, parts and torque. Contact Kobelt or your local Kobelt partner to review this information.

*Table 2: Balanced and Unbalanced Cylinders Installation Information*

<b>Model</b>	<b>A</b> in [mm]	<b>B</b> in [mm]	<b>C</b> in [mm]	<b>D</b> in [mm]	<b>G</b> in [mm]	<b>L</b> in [mm]	<b>M</b> in [mm]	<b>N</b> in [mm]	<b>T</b> in [mm]
<b>7040</b>	2.70 [68]	3.95 [100]	2.00 [51]	3.19 [81]	4x 0.34 [9]	0.25 [6]	3.29 [83]	1.77 [45]	0.95 [24]

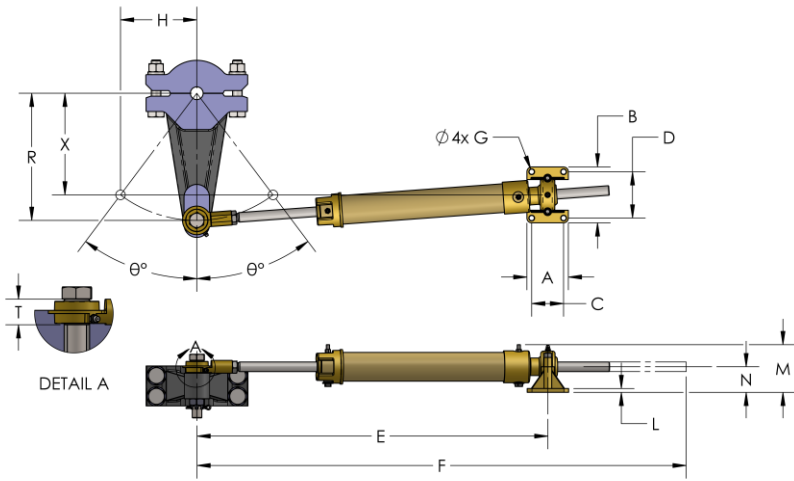

Figure 2: 7040 Balanced Cylinder Installation Diagram

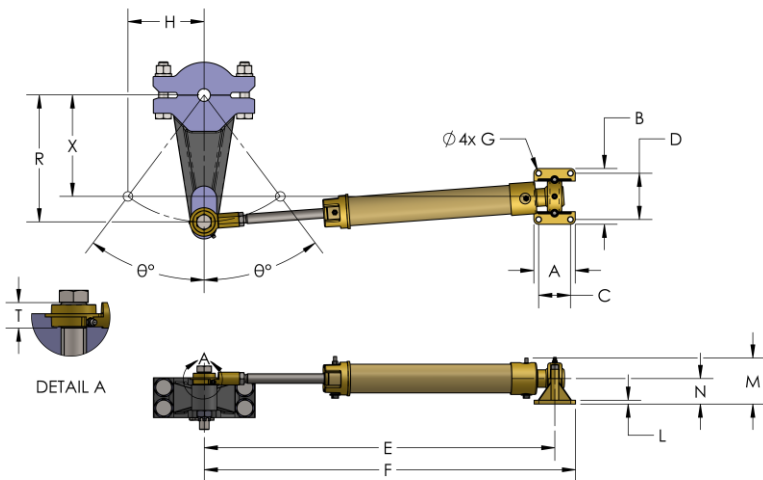

Figure 3: 7040 Unbalanced Cylinder Installation Diagram



Table 3: Balanced Cylinders- Rudder Angle ( $\theta$ ) 37 °

Model	Stroke in [mm]	*Torque Lbs.ft [kg.m]	Displacement In <sup>3</sup> [cm <sup>3</sup> ]	R in [mm]	X in [mm]	H in [mm]	E in [mm]	F in [mm]	Weight Lbs [kg]
7040	5.5 [140]	547 [76]	7.7 [126]	4.570 [116]	3.649 [93]	2.75 [70]	16.5 [419]	20.83 [529]	7.7 [3.5]
	7.5 [191]	745 [103]	10.4 [170]	6.231 [158]	4.976 [126]	3.75 [95]	19.5 [495]	25.83 [656]	8.4 [3.8]
	10 [254]	994 [137]	13.9 [228]	8.308 [211]	6.635 [168]	5.0 [127]	23.25 [591]	32.08 [815]	9.4 [4.3]

\*Torque is based on one cylinder at 1200 psi (83 bar) at 35 degree.

Table 4: Balanced Cylinders- Rudder Angle ( $\theta$ ) 47 °

Model	Stroke in [mm]	*Torque Lbs.ft [kg.m]	Displacement In <sup>3</sup> [cm <sup>3</sup> ]	R in [mm]	X in [mm]	H in [mm]	E in [mm]	F in [mm]	Weight Lbs [kg]
7040	5.5 [140]	388 [54]	7.8 [128]	3.760 [95]	2.564 [65]	2.75 [70]	16.5 [419]	20.83 [529]	7.7 [3.5]
	7.5 [191]	529 [73]	10.6 [174]	5.127 [130]	3.497 [89]	3.75 [95]	19.5 [495]	25.83 [656]	8.4 [3.8]
	10 [254]	706 [97]	14.1 [231]	6.837 [174]	4.663 [118]	5.0 [127]	23.25 [591]	32.08 [815]	9.4 [4.3]

\*Torque is based on one cylinder at 1200 psi (83 bar) at 45 degree.

Table 5: Unbalanced Cylinders- Rudder Angle ( $\theta$ ) 37 °

Model	Stroke in [mm]	*Torque Lbs.ft [kg.m]	Displacement In <sup>3</sup> [cm <sup>3</sup> ]	R in [mm]	X in [mm]	H in [mm]	E in [mm]	F in [mm]	Weight Lbs [kg]
7040	5.5 [140]	1208 [167]	16.9 [277]	4.570 [116]	3.649 [93]	2.75 [70]	16.5 [419]	17.85 [453]	7.2 [3.2]
	7.5 [191]	1647 [228]	23.1 [378]	6.231 [158]	4.976 [126]	3.75 [95]	19.5 [495]	20.85 [530]	7.7 [3.5]
	10 [254]	2196 [304]	30.8 [505]	8.308 [211]	6.635 [168]	5.0 [127]	23.25 [591]	24.60 [625]	8.4 [3.8]

\*Torque is based on two cylinders at 1200 psi (83 bar) at 35 degree.

Table 6: Unbalanced Cylinders- Rudder Angle ( $\theta$ ) 47 °

Model	Stroke in [mm]	*Torque Lbs.ft [kg.m]	Displacement In <sup>3</sup> [cm <sup>3</sup> ]	R in [mm]	X in [mm]	H in [mm]	E in [mm]	F in [mm]	Weight Lbs [kg]
7040	5.5 [140]	858 [119]	17.2 [282]	3.760 [95]	2.564 [65]	2.75 [70]	16.5 [419]	17.85 [453]	7.2 [3.2]
	7.5 [191]	1170 [162]	23.4 [383]	5.127 [130]	3.497 [89]	3.75 [95]	19.5 [495]	20.85 [530]	7.7 [3.5]
	10 [254]	1560 [216]	31.2 [511]	6.837 [174]	4.663 [118]	5.0 [127]	23.25 [591]	24.60 [625]	8.4 [3.8]

\*Torque is based on two cylinders at 1200 psi (83 bar) at 45 degree.

## 4.2 HYDRAULIC

Before connecting the hydraulic lines to the cylinder ensure all the hydraulic lines in the steering system have been flushed and that the hydraulic oil is free of any contamination, which may enter the system and cause it to fail.

Hydraulic oil (ISO32) is recommended for steering systems. Depends on ambient temperature it can be one grade higher or lower. (ISO46 for hot climate and ISO 16 for cold climate). Avoid using transmission or brake oil.

Two hydraulic connections are required to the cylinders. Two lines connect the main steering lines. Shut off or isolation valves for these lines are recommended. If the system failed, the isolation valves can be shut.

### **NOTICE**

All piping and hoses must be flushed prior to connection. Failure to do so can result in damaged components and seals.

The piping to the steering cylinder should be minimum 1/4" nominal size with a suitable wall thickness to safely withstand the operating pressure. The Port and Starboard steering lines should have a pressure rating of 2250 psi minimum. Secure the piping against vibration with pipe clamps spaced every 3 feet [1 m].

## 5 COMMISSIONING

### 5.1 FLUSHING

Before subjecting the steering system to full hydraulic pressure, the lines must be flushed to an ISO 4406 cleanliness rating of 20/18/15.

### 5.2 INSPECTION & FUNCTION TEST

Before putting the vessel into service perform a quick inspection and function test of the unit:

- Ensure that all mounting bolts are properly installed.
- Bleed fittings are tight.
- All hydraulic lines are connected and tight.
- Secure fittings and make sure there are no leakage.
- Check cylinder position with General Arrangement Drawing.
- Check tiller bolt is installed and secured.

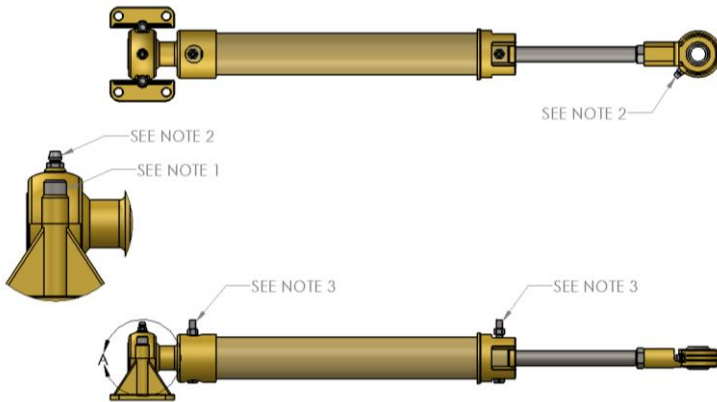

#### NOTES:

1. APPLY LOCTITE 243 AND TIGHTEN TO **75 lb.in.**
2. GREASE PERIODICALLY.
3. AIR BLEED FITTING, ALWAYS FACE UP.

### 5.3 HYDRAULIC FILL & BLEED

After the hydraulic connections have been completed, open all isolating valves and allow enough time for the cylinder and lines to fill with oil.

Hydraulic cylinder bleeding is the process of removing trapped air from the cylinder.

In most of the cases, air will enter the cylinder during installation. So, utmost care is required during the installation of a hydraulic system. Failure of the load control valve can be another reason for air being entered the cylinder.

Hydraulic cylinder bleeding includes two stages. In the first stage, the trapped air was brought towards the top of the cylinder. In the second stage, those air is removed through the bleed valve. The detailed procedure is discussed below.

- Operate the unit in manual mode and confirm rudder moves in the correct direction.
- Extend the hydraulic cylinder completely to bring air towards the top of the cylinder. The trapped air will naturally come to the top if you leave the cylinder extended for some specific time.
- The air will escape through the bleeder nut. So, locate the bleeder nut and loosen the nut until the cylinder begins to retract.
- Tighten the bleeder nut, when you find any discharge of hydraulic fluid through the nut. The discharge of fluid will indicate the removal of trapped air.
- Repeat the same steps for the other end of cylinder.
- Clean the surface of the hydraulic cylinder properly before starting the operation.

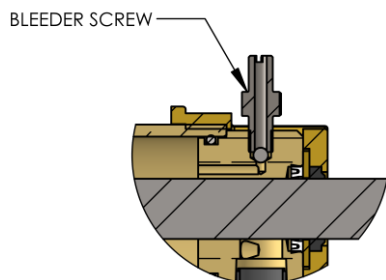

## 6 MAINTENANCE

### 6.1 PREVENTATIVE MAINTENANCE

- Monthly (12 times per year)
  - Inspect connections for leaks.
- Every (6) six months (2 times per year)
  - Grease
- Quarterly (4 times per year)
  - Verify adequate oil level.

### 6.2 RECOMMENDED SPARE PARTS

As a minimum Kobelt recommends the following spare parts are on-hand:

*Table 2: Recommended Spares*

RECOMMENDED SPARES		
QTY	DESCRIPTION	KOBELT PART #
1	CYLINDER 7040-BALANCE REPAIR KIT <ul style="list-style-type: none"> <li>• O-rings, U-Cups, Wear Ring, Rod Wiper</li> </ul>	7040-B-RK
1	CYLINDER 7040-UNBALANCE REPAIR KIT <ul style="list-style-type: none"> <li>• O-rings, U-Cups, Wear Ring, Rod Wiper</li> </ul>	7040-U-RK

When purchasing spare parts refer to Appendix A: Parts List at the back of this manual for Kobelt component Part Numbers.

## NOTICE

It is recommended that any required service work on a Kobelt product be performed by a factory authorized service representative. Please contact the nearest Kobelt authorized distributor for assistance.

---

## 7 WARRANTY

---

Kobelt Manufacturing Co. Ltd. ("Kobelt") warrants the Products and Parts manufactured by Kobelt to be free from defects in workmanship or material and that said products are designed mechanically and functionally to perform to specifications.

This warranty is effective providing:

- The equipment is used within the intended operating conditions and in accordance with Kobelt recommendations
- The equipment is installed according to equipment diagrams, specifications and recommendations which Kobelt has provided

This warranty becomes invalid if the factory supplied serial number has been removed or altered on the product. This warranty does not cover cosmetic damage or damage caused by an act of God, accident, misuse, abuse, negligence or modification of any part of the product. This warranty does not cover damage due to improper operation or maintenance, connection to inappropriate equipment or attempted repair by anyone other than an authorized Kobelt representative.

Upon identification of a potential issue or defect with a Kobelt Product or Part, the Warranty Applicant ("Applicant") must immediately contact Kobelt and describe the issue in writing, by letter, fax, email or other electronic conveyance. Kobelt will then assess the cause of the defect and determine warranty applicability and appropriate remediation.

If any part is found to be defective, Kobelt will replace said part FOB the Kobelt factory provided that any such defective part is returned by the Buyer with freight and applicable forwarding charges prepaid by the Buyer. Kobelt's sole obligation to the Applicant will be to repair or replace the defective part with same or similar product, to a maximum value of the list price of the product or part. The Kobelt warranty does not cover labour charges, travel or any other associated expenses.

All Products and Parts manufactured by Kobelt, are subject to a warranty against manufacturer's defects in materials or workmanship for a period of two (2) years from the date of purchase.

Kobelt will be responsible for all Products or Parts sold by Kobelt but manufactured by 3<sup>rd</sup> party manufacturing companies. However, these products and parts are subject to applicable 3<sup>rd</sup> party warranties and may not be the same as the Kobelt warranty.

## 8 APPENDIX A: PARTS LIST

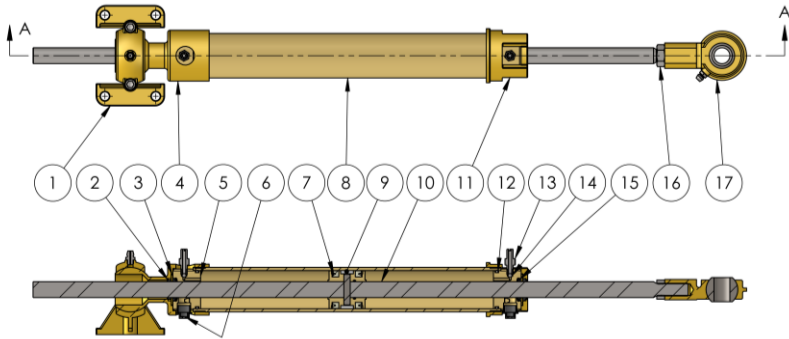

Figure 2: 7040 Balance Cylinder Parts Diagram

Table 3: 7040 Balance Cylinder Parts List

		Model No.:	7040 Balance
		Part No.:	7040-BXX*
ITEM	QTY	DESCRIPTION	
1	1	TRUNNION FOOT ASSEMBLY	7040-0102
2	2	WIPER	7040-B-RK
3	2	RETAINING WASHER	7040-0010
4	1	TRUNNION END CAP	7040-0003-ULT
5	2	ROD GUIDE	7040-0007
6	2	PLASTIC PLUG, NPT	7039-3042
7	2	U CUP	7040-B-RK
8	1	CYLINDER TUBE	7040-XX06
9	1	WEAR RING	7040-B-RK
10	1	PISTON ROD SUB-ASSEMBLY	7040-BXX-SUB
11	1	END CAP	7040-0001-ULT
12	2	O-RING	7040-B-RK
13	2	BLEEDER SCREW	7040-0011
14	2	BALL	1301-0005
15	2	U CUP	7040-B-RK
16	1	JAM NUT	1022-0264
17	1	ROD BALL END ASSEMBLY	7040-0004

XX\*: Cylinder stroke

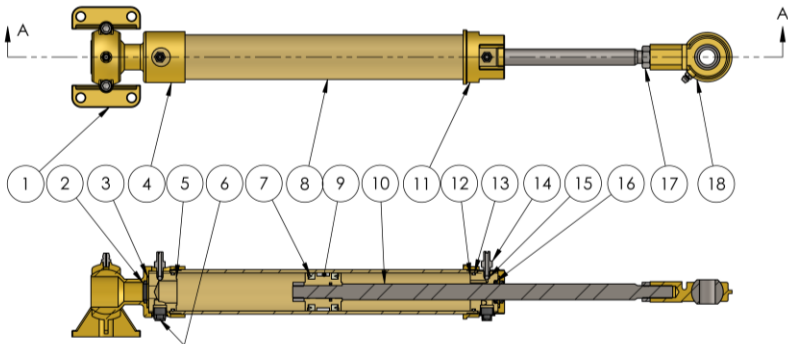

Figure 3: 7040 Unbalance Cylinder Parts Diagram

Table 6: 7040 Unbalance Cylinder Parts List

		Model No.:	7040 Unbalance
		Part No.:	7040-UXX
ITEM	QTY	DESCRIPTION	
1	1	TRUNNION FOOT ASSEMBLY	7040-0102
2	2	WIPER	7040-U-RK
3	2	RETAINING WASHER	7040-0010
4	1	TRUNNION END CAP	7040-0003-ULT
5	2	REAR END CAP	7040-0107
6	2	PLASTIC PLUG, NPT	7039-3042
7	2	U CUP	7040-U-RK
8	1	CYLINDER TUBE	7040-XX06
9	1	WEAR RING	7040-U-RK
10	1	PISTON ROD SUB-ASSEMBLY	7040-UXX-SUB
11	1	END CAP	7040-0001-ULT
12	2	ROD GUIDE	7040-0007
13	2	O-RING	7040-U-RK
14	2	BLEEDER SCREW	7040-0011
15	2	BALL	1301-0005
16	2	U CUP	7040-U-RK
17	1	JAM NUT	1022-0264
18	1	ROD BALL END ASSEMBLY	7040-0004



*Page Intentionally Left Blank*

*Page Intentionally Left Blank*

*Page Intentionally Left Blank*

# ***KOBELT***

**Kobelt Manufacturing Co. Ltd.**

8238 129th Street  
Surrey, British Columbia,  
Canada, V3W 0A6

Sales Tel: +1-604-572-3935

Fax: +1-604-590-8313

Email: [sales@kobelt.com](mailto:sales@kobelt.com)

Website: [www.kobelt.com](http://www.kobelt.com)

Made in Canada / Printed in Canada