

Valves and Thru-Hull Fittings Installation

We recognize that many different combinations of valves and fittings are employed in the marine industry. This bulletin is intended to provide recommendations for the safest installation of thru-hull fittings and related components.

Installation Comments

SEACOCK INSTALLATION

FIGURE-1 shows a sample seacock installation with two possible methods of mechanically fastening shown. On the left side is the method of bolting through the flange, backing block, and hull. On the right side is the method of bolting through the flange and into the backing block, but not through the hull. We consider either method acceptable, as both represent a safe and secure installation.

STEP-1: Cut a hole through the hull and backing block slightly larger than the thru-hull fitting OD, and measure the thickness of the hull and backing block together (Dimension-A).

STEP-2: Measure the total thread depth of the female NPS threads in the bottom of the seacock (Dimension-B). Add A and B together.

STEP-3: If the thru-hull neck length exceeds this dimension cut the thru-hull length 1/4" shorter than A + B. If the thru-hull length is shorter than A + B by more than 1/4", use a thinner backing block or use an Extra-long thru-hull fitting (GROCO THXL Series)

STEP-4: To prevent the seacock from turning, bolt through the seacock flange into a backing block, or bolt through the hull from the outside in, and through the seacock flange. Figure-1 shows both methods. Use hex nuts, flat washers and lock washers as shown.

It is acceptable to fasten pipe fittings directly to the seacock, but DO NOT install components such as pumps, valves, or strainers directly on top of the seacock unless these components are independently supported.

IN-LINE VALVE INSTALLATION

GROCO does not recommend the use of in-line valves as seacocks for these reasons:

1. An in-line valve has no means of attachment to the vessel hull or backing block, so the valve can turn or loosen from the thru-hull fitting with vibration or with normal use.
2. If the connected thru-hull fitting becomes damaged or broken, as might occur if the vessel struck a submerged or floating object, or if

the fitting was inadvertently damaged or broken inside the hull, there would be no way to shut off the flow of water into the vessel.

3. In-line valves have NPT threads, which are not compatible with NPS threaded thru-hull fittings (unless the thru-hull fitting is machined with "Combination Thread". Installing an in-line valve onto a thru-hull fitting will create a mismatch of threads resulting in minimal thread engagement between valve and fitting, and an unsafe installation. Property damage, personal injury, or both could occur. If you choose to utilize an in-line valve as a seacock, the thru-hull fitting used must have "Combination Thread".

FIGURE-2 shows a sample installation of an in-line valve used as a seacock.

STEP-1: Choose a location that is out of the way of foot traffic.

(continued on reverse side)

FIGURE-1 SEACOCK AND THRU-HULL FITTING INSTALLATION

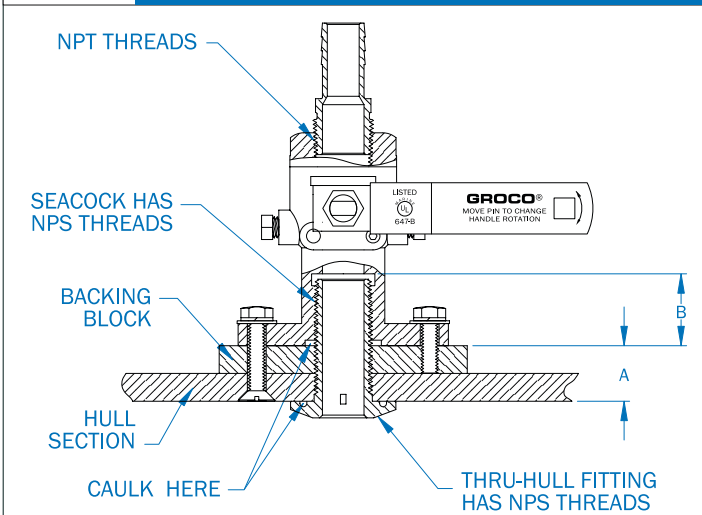
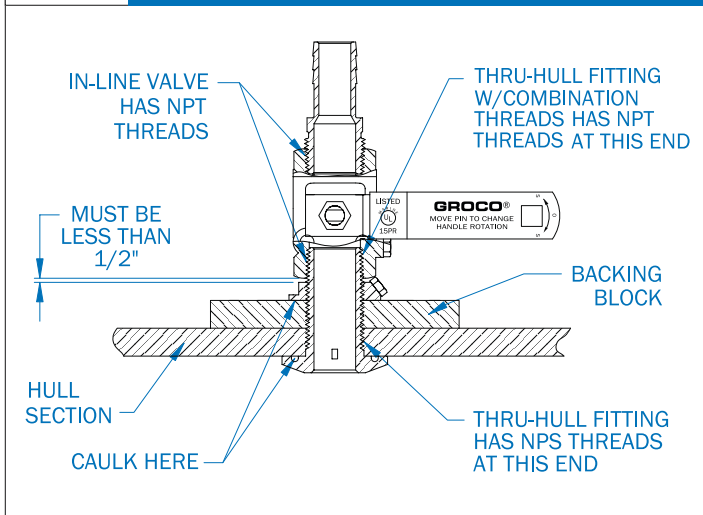

FIGURE-2 IN-LINE VALVE AND THRU-HULL FITTING INSTALLATION



CONTINUED FROM FRONT

STEP-2: Cut a hole through the hull and backing block slightly larger than the thru-hull fitting OD.

STEP-3: Insert the thru-hull into the hole and tighten the lock nut.

STEP-4: Apply TFE thread tape to the thru-hull fitting and screw on the in-line valve securely. Use a thru-hull installation tool (GROCO THT-530) to hold the thru-hull during valve tightening. If the distance between the lock nut and the in-line valve exceeds 1/2", remove the valve and thru-hull lock nut, and use a thicker backing block.

do not use pliers to hold the threaded thru-hull neck while tightening the in-line valve.

do not cut the thru-hull length, as this will remove part or all of the "Combination Thread"

do not over-tighten the in-line valve on the thru-hull fitting. This may weaken or break the fitting.

do not install components such as pumps, valves, or strainers directly on top of the in-line valve unless the components are independently supported.

GLOSSARY OF TERMS

NPS THREADS

Standard straight pipe threads that when assembled with other NPS threaded components will provide free and loose fitting mechanical joints without pressure tightness.

NPT THREADS

Standard tapered pipe threads that when assembled with other NPT threaded components and a sealer will produce a pressure tight joint.

COMBINATION THREADS

Non-standard pipe threads on a thru-hull fitting comprised of NPT threads at the lead end, blending smoothly into NPS threads for the remainder of the fitting to the flange end.

THRU-HULL FITTING

A flanged NPS-threaded fitting of sufficient length to penetrate hulls of various thickness, and to accept a seacock having NPS threads. The flange is usually grooved to accept caulking material, and is drawn tight against the outside of the hull by the fastening of the seacock inside the hull. A thru-hull fitting is for above or below waterline use, and may be machined with "Combination Thread".

SCOOP THRU-HULL FITTING (SPEEDBOAT STRAINER)

A flanged NPS-threaded fitting whose flanged end has cast slots to provide coarse primary filtration and positive pressure into the connected plumbing system while the vessel is under way. A scoop thru-hull fitting is for below waterline use only, may be machined with "Combination Thread", and is drawn tight against the outside of the hull by the fastening of the seacock inside the hull. Mounting holes are provided around the perimeter of the flange to enable mechanical fastening of the fitting to the hull.

HOSE THRU-HULL FITTING:

A flanged NPS-threaded fitting of sufficient length to penetrate hulls of various thickness for the purpose of making an above waterline hose connection. The flange is usually grooved to accept caulking material, and is drawn tight against the outside of the hull by the fastening of the locknut inside the hull. The end opposite the flange end has a hose barb of sufficient length for dual hose clamps.

SEACOCK

A valve with a mounting flange perpendicular to the passage through the valve, for use to shut off the flow of water through the vessel hull. Female NPS threads are provided at the flanged outboard end, female NPT threads at the inboard end, and machined holes are provided in the flange through which the seacock is mechanically fastened to a backing block or through the vessel hull, making the seacock an integral part of the hull structure.

IN-LINE VALVE

A valve without a mounting flange, which is designed for use to shut off the flow of fluids in a plumbing system contained within the vessel. Female NPT threads are provided at both ends that are compatible only with pipe or fittings with male NPT threads, or with "Combination Thread".

BACKING BLOCK

A rigid disc made of wood, plastic, fiberglass, or other water-resistant material that is bonded to the inside of the hull at the location of a through hull penetration. The disc adds thickness and strength, and provides a solid platform through which the seacock flange can be mechanically fastened, effectively spreading the load exerted by the seacock over the increased area of the disc.